

# Life cycle assessment as an evaluation tool for carbon reduction techniques in marine industry

Haibin Wang<sup>a,\*</sup>, Peilin Zhou<sup>a,b</sup>

a- Department of Naval Architecture, Ocean and Marine Engineering, University of Strathclyde, UK

b- Zhejiang University, 1 Zheda Road, Zhoushan, Zhejiang Province, 316021, China

\* Corresponding author; e-mail: haibin.wang.100@strath.ac.uk, phone: +44(0)1415484047

## Abstract

Global warming has been drawing researchers' attention for decades and in marine industry many different strategy and technologies are introduced to mitigate the global warming effect. As a main contributor to global warming, carbon dioxide has been targeted as a significant emission to reduce from marine activities and there are many carbon emission reduction technologies introduced to shipping. However, the results of the reduction are varied and an evaluation tool to investigate their performances in a long term are necessary. Life cycle assessment is an evaluation method considering a product or system's life span, from cradle to grave, covering all the activities which generate carbon emissions. While applying new carbon reduction technologies, the emissions from different activities are estimated and determined through life cycle assessment. Considering the related costs, a life cycle economic assessment can illustrate the overall savings with the application of carbon emission reduction technologies. Currently the assessments have been conducted to evaluate the applying of hybrid propulsion system, selection of engine configuration, utilization of solar panel array, adoption of carbon capture system, determination of maintenance strategy and so on. The results have indicated the performances of these carbon reduction methods from the perspectives of environment and economy which indicates that life cycle assessment is a feasible and comprehensive evaluation tool for the performance evaluations on carbon reduction techniques.

**Keywords:** Life cycle assessment, life cycle cost assessment, carbon reduction techniques, ship performance evaluation.

## 1 INTRODUCTION

Global warming has become one of the most concerned issue in 21st century. It has drawn attentions of professionals, such as researcher, politics, manufacturers and entrepreneurs from many fields transportation, manufacturing, environmental protection and management. For international marine shipping as an example, the CO<sub>2</sub> released in 2012 are estimated to be only 2.2% of global CO<sub>2</sub> emissions but International Maritime Organization (IMO) has designed and developed new regulations to make mandatory the Energy Efficiency Design Index (EEDI) for new ships and the Ship Energy Efficiency Plan (SEEMP) for all ships over 400 gross tonnages in 2013 [1]. Recently, there are large numbers of carbon emission reduction technologies introduced to marine industry to meet the IMO's regulations. Technologies such as hybrid power system, engine system re-configurations, solar energy, carbon capture on ships and hull maintenance strategy, has been evaluated using life cycle assessment (LCA) approach to indicate the performance of the carbon reduction technologies (CRT) considering from the cradle to grave of ships, system or products covering their environmental and economic impacts on the shipping performance. This paper will present the application of LCA on the CRT performance evaluation and provide a guide to shipyard, ship owner and policy makers about the availability, feasibility, comprehensiveness and fineness of LCA method.

## 2 LITERATURE REVIEW

This section will review the research works respectively on CRT applications and life cycle assessment. It is because there is limited research carrying out LCA on CRT applications for marine industry. This research reviews applications to identify the advantages of CRT applications. The applications of LCA in different industries are reviewed to indicate the availability of the method.

### 2.1 Carbon reduction technologies

Carbon reduction technologies are method, technique, system and strategies which aim to reduce the carbon emission release. The carbon emissions can be carbon dioxide (CO<sub>2</sub>), methane (CH<sub>4</sub>), carbon monoxide (CO) and so on. The purpose of reducing carbon emission is to mitigate the severe situation of climate change and as CO<sub>2</sub> is the largest contributor to climate change/global warming, studies on CO<sub>2</sub> emission attracts more and more attentions.

Focusing CO<sub>2</sub> emissions, there are many different ways to achieve CO<sub>2</sub> reduction and basically increasing energy efficiency and applying non-fossil fuels are two main types. Increase energy efficiency will lead low fuel consumption so that low CO<sub>2</sub> generated. To reduce CO<sub>2</sub> released, it is also an option to increase the proportion of non-fossil fuel for ship propulsion. In this review,

To change the propulsion from conventional type driven by engines and generators, a hybrid system is

usually preferred which utilises energy from engines and gen-sets together with that from other sources for propulsion. Researchers have investigated the application of battery packs on board ferries to evaluate the impact of operation modes (i.e. power demand distributions from engines and batteries) on environmentally friendly and economic feasibility [2–5]. The outcomes and comparisons from this research highlighted the benefits of the application of battery packs on CO<sub>2</sub> reduction in the marine industry.

Apart from battery applications, there is only a limited amount of research focusing on the application of renewable energy on ships such as electrofuel, fuel cells, wind and solar energy. One of the most considered energy is the solar and utilisation of solar panels can absorb and use solar energy as a supplement to the propulsion system. An application [6] of solar panel system was carried out in the USA to utilize photovoltaic solar system under extreme offshore environment. Two types of solar system (crystalline and thin film) were compared with other renewable energy systems, such as wind, tidal and wave energy. Their findings showed that thin film solar panel system is the most cost effective systems. Table 1 indicates the latest hybrid vessels using different propulsion system: generators, battery packs, solar panel system and wind (kite) system.

*Table 1 A list of latest hybrid vessels and their propulsion system*

General information			Hybrid methods
Name	Type	Year	
Hallaig [7]	Ferry	2012	Generator + battery
Catriona [8]	Ferry	2013	Generator + battery
Lochinvarl [9]	Ferry	2013	Generator + battery
Viking Grace [10]	Cruise ship	2013	Generator + wind
Solar Voyager [11]	Kayak	2016	Solar
Victoria of Wight [12]	Ferry	2018	Generator + battery
Roald Amundsen [13]	Ferry	2019	Generator + battery
Color Line [14]	Cruise ship	2019	Generator + battery
Duffy London [15]	Yacht	2020	Solar + battery

For carbon reduction method, there are many different technologies as mentioned previously focusing on different parts of ships, for examples, coating applications, route optimizations, speed optimizations and after treatment. Ling-Chin and Roskilly has worked on marine propulsion system as well [16]. Bicer and Dincer investigated the application of hydrogen in marine vessels [17].

There are many different ways of carbon capture method could help reduce carbon emission released: pre-combustion, post-combustion and oxy-fuel combustion methods. However, there are very a few applications on marine vessels. This paper tests authors' previous work, carbon solidification on ship, and applies LCA model to evaluate the economic results in order to compare with the results from previous work.

To investigate the long-term economic and environmental impacts in different selections or decisions

for hull maintenance, one of the key target of this paper is to present and compare maintenance strategies for ship hull that is susceptible to corrossions which may adversely diminish the structural strength. Since optimal hull maintenance is essential to the ship operators, a few relevant research on hull maintenance were introduced, including the follow:

Garbatov and Soares have used probabilistic analysis to determine the optimum repair interval and times with a minimized total cost [17, 18]. Wang and his team carried out a research on an estimation method for corrosion rate of oil tanker structure which is supported by Garbatov's works using of Weibull distribution [21]. A number of research on the corrosion rate for aging ship have already carried out by Pusan National University, American Bureau of Shipping and Chevron Shipping Company LLC in order to evaluate the time-dependent corrosion in ship structure [20, 21]. Gratsos and Zachariadis [24]proposed to increase the corrosion allowance in ship particular sections which have inadequate strength.

All these researches are trying to point out the efforts from marine industry to mitigate the global warming effect by reducing the energy consumption and CO<sub>2</sub> release. In the following sections (section 3, 4 and 5), the principles, application and performances will be presented.

## 2.2 LCA as a method

One of the objectives of this paper is to investigate the environmental and economic impact of CRT applications to marine vessels. According to previous research stated in Section 2.1, it is obvious that hybrid power systems for marine vessels is an interesting topic which has been considered and investigated by many researchers. However, there is only a limited number of research carried out to apply renewable energy systems on marine vessels and most of them only focused on the purchase and operation of renewable energy devices (such as solar panel system). The applications of CCS system and optimization of hull maintenance strategies are also considered for carbon emission reductions. Therefore, to comprehensively evaluate the environmental and economic impact of a system or device application, Life Cycle Assessment (LCA) and Life Cycle Cost Assessment (LCCA) will be introduced.

The aim of LCA is to evaluate the environmental impact of a system or a product by considering the whole life stages, including construction, operation, maintenance and scrapping. Taking emission flows, cash flows and energy flows into account, LCA could present the life cycle emission released, initial investment and energy consumptions inside the assessment boundary.

Like in other industries, LCA has drawn a considerable attention in the marine industry. LCA was applied to quantify the willow growth on river buffer zones to find out the benefit of willow cultivation [25]. To evaluate the energy consumption and environmental impact of edible protein energy return on investment (ep-EROI) for fishing industry, LCA was used by Vázquez-Rowe's research group in Spain and expected results provided advice for the EU Common Fisheries Policy [26]. Fredga and Maler [27] also established a full scope of LCA model to assess

the state-of-art and under developed biofuel application considering energy, material and emission flows and comprehensive analysis and precise results were achieved. There is a number of LCA study focusing on renewable energy systems in many countries such as Brazil, Libya, Nigeria, Thailand and so on [28–31].

LCA has also been used to evaluate the environmental impact of marine activities by many researchers in order to investigate and assess the performances of different alternatives such as selections of various retrofitting options, propulsion systems and even paper stream treatments[32–37], With the help of LCA, the overall environment protection performance could be optimized by optimization of raw material and energy consumption, and recycle processes [38].

### 3 METHODOLOGY

According to the ISO standard, a LCA analysis should fundamentally include the definition of research/analysis objectives and boundaries, life cycle inventory analysis (LCI), life cycle impact analysis (LCIA) and life cycle interpretation [37, 38]. The framework of LCA analysis is presented in Figure 1.

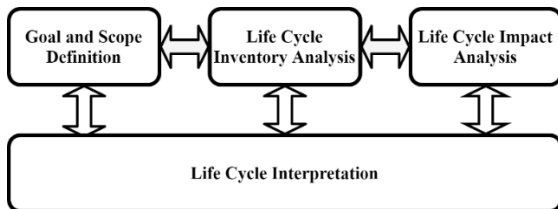

Figure 1 The schematic chart of life cycle assessment

To conduct a LCA analysis, the first step is to define its objectives and boundaries. In a typical research study, the objective is set up to determine a specific performance or cost of a system or product and it is similar to a LCA study which is to obtain the environmental impact of a system or product. However, there are so many different types of environmental impacts existing such as global warming potential (GWP), acidification potential (AP) and eutrophication potential (EP), hence the purpose of the study is essential. After definition of the objective, the scope and boundary of the LCA analysis should be considered. With the objective defined, certain types of potential (e.g. GWP, AP or EP) should be selected and considered as primary research objects. Although there will be many emissions and pollutions under evaluation, many others have been neglected since they have insignificant impact on the primary objects. Then based on the potentials selected, a functional unit should be set up as a standard to carry out the evaluation and comparisons of different scenarios.

A normalization process will be conducted to convert different emissions which have contributions to different potentials into one type of emissions. According to the CML database [41], all the emissions which make contributions to global warming will be normalized and converted in to an equivalent quantity of CO<sub>2</sub> and the unit is kg CO<sub>2</sub> equivalent. For AP and EP, the fundamental pollutions are sulphur dioxide and phosphate (SO<sub>2</sub> and PO<sub>4</sub><sup>3-</sup>). Although the functional unit could be these equivalent units, they can also be set up by the end users

based on their objective. The normalization processes help to simplify the set up process which usually is based on the normalized units or extension of them. Another important part in goal and scope definition is to define the system boundary. Apart from constraining the scope by the relevant emissions, the differences between alternatives could also help reduce the LCA scope so that a compact but comprehensive LCA model can be established without considering repeated, redundant and less effective parts of the system or product. Therefore, reasonable scope should be made in order to neglect these unnecessary parts. Furthermore, assumptions should be made to progress the analysis because sometimes real data cannot be retrieved or provided. Usually assumptions should be made or advised by the system or product owners, manufacturers and operators.

After the definition of goal and scope, life cycle inventory analysis can be conducted as shown in the schematic diagram in Figure 2. The figure starts with the defined goal and scope where an initial LCA plan has been selected and determined as mentioned in previous paragraph. With this plan, data involved in the plan could be collected, normalized and aggregated so that initial outcomes could be determined. However, the scope of the LCA analysis will be expanded or trimmed because the relevant data maybe available or unavailable sometimes. After adjusting the scope based on data availability, similar processes of data collection, normalization and aggregation will be conducted so that a modified but complete inventory of a LCA analysis can be obtained.

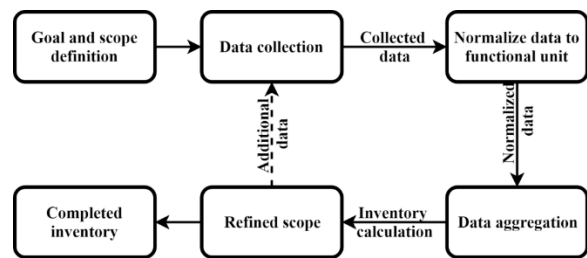

Figure 2 Schematic chart of life cycle inventory analysis

The LCI analysis will be used as a fundamental for LCIA analysis which consists of three main steps:

- Selection: impact categories chosen including indicators and characterization models;
- Classification: LCI results assigned to the selected impact categories;
- Characterization: calculation using LCI results as input and characterization models to determine results based on category indicator.

In the life cycle interpretation phase, sensitivity analysis will be carried out to evaluate how the significant inputs impact the established LCA processes and results, i.e. midterm and final results. The results will indicate the significant issues based on the LCI and LCIA analysis which usually provide end users recommendations on the selections of different alternatives. Furthermore, the conclusions, limitations and recommendations of the LCA analysis should be provided in this interpretation processes which illustrate not only the decisions made but also the constraints of the analysis.

The structure of LCA analysis is presented and described which covers from the goal definition to sensitivity analysis. Usually a benchmark study is carried out for a selected vessel operated under a given or assumed operation profiles with power requirement, fuel consumption and voyage durations. The overview

procedure of one example case is presented in Figure 3. This figure shows the where the data come from, what data are required, the processes considered in different life stages and the outcome of the analysis. In the section 5, the details, results and comparison of LCA studies will be presented.

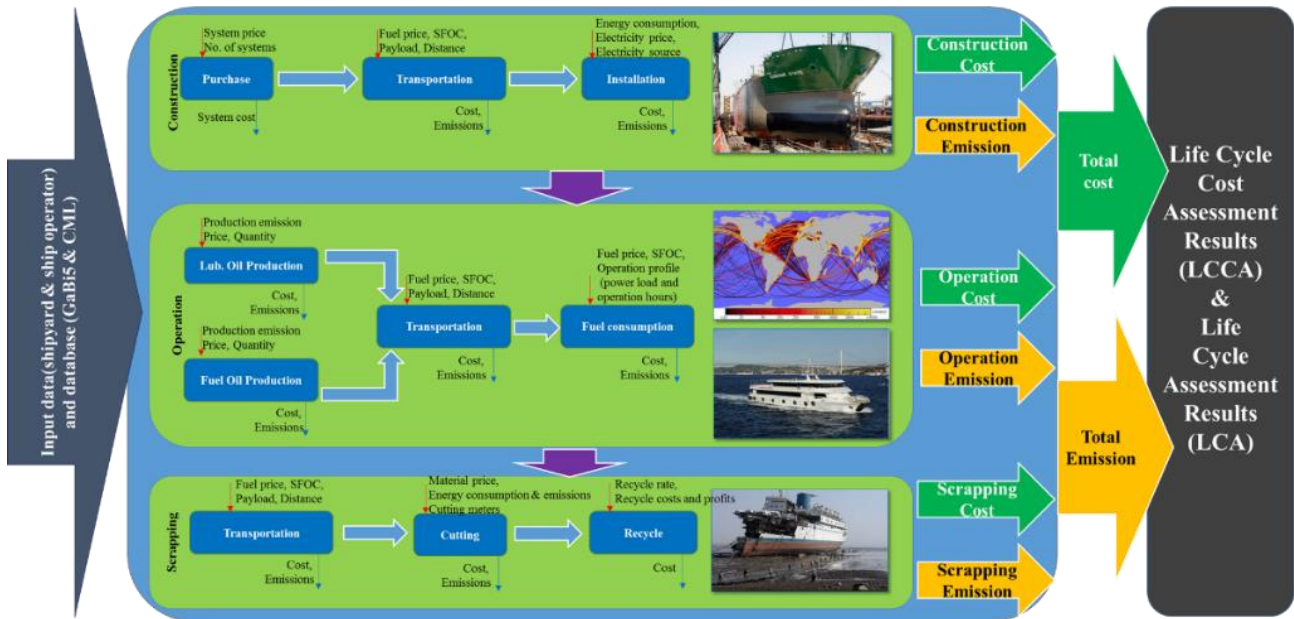

Figure 3 Overview procedure of LCA study

#### 4 CARBON REDUCTION TECHNOLOGIES (CRT)

In this section, the details of several CRTs are presented covering their principles and applications. In the following section, case studies will be carried out so that the performances of these technologies can be determined for the sake of evaluation.

##### 4.1 Hybrid Propulsion System

The hybrid propulsion system is based on the conventional diesel electrical propulsion system which is attached by battery packs to provide storage energy to drive motors for propulsion. For a diesel mechanical system, the principle is totally changed from direct driving to electrical driving.

In Figure 4, the layout of three different systems are presented to indicate the principles. Apparently, the system is getting complex and involving more component and sub-systems: For DM system, the propellers are driven by two main engines and the mechanical power are transmitted by shafts. This is considered to be most energy efficient method from the perspective of energy generation in M/Es. However, due to the complex of operation, a various power requirement will be necessary which decrease the energy efficiency of DM system. It is because the engines will have a high specific fuel oil consumption (SFOC, g/kWh) and to avoid low engine output load and save fuel oil, switching from mechanical driving to electrical driving makes the engine output load in a favour region with lower SFOC.

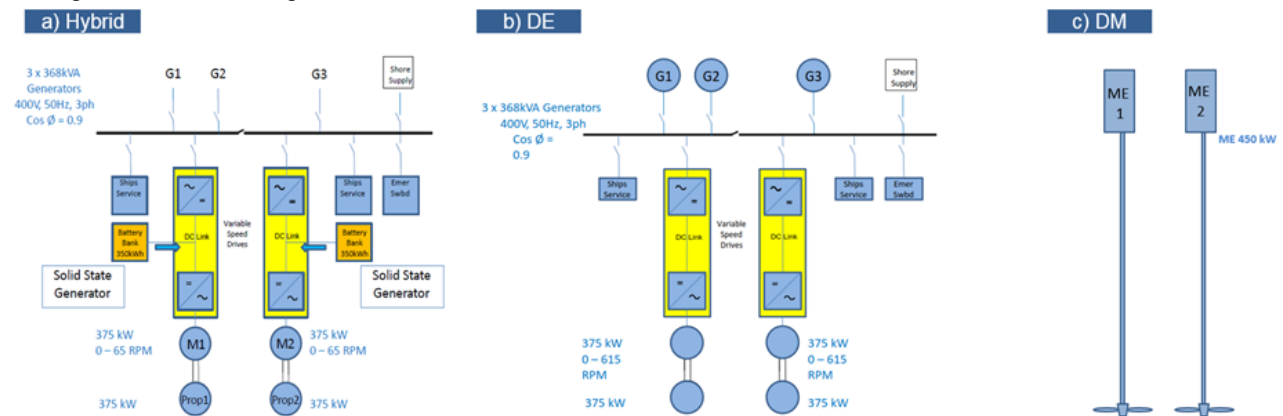

Figure 4 Drawing for various propulsion systems

In this study, a case ferry is selected to couple with three different propulsion systems, DM, DE and hybrid to evaluate their performances (life cycle impact and life cycle cost impact). The specification and the operation profile of the case ferry are presented in Table 2. The LCA model established is presented in Appendix 1 considering life stages (construction, operation, and scrapping) and main activities (transportation, purchase, operation, energy supply and so on). The result of this study is presented in Figure 5 which indicates the hybrid system, with the support of battery packs, has a lowest

life cycle environmental and cost impact among three systems. When using alternative options, the estimated increases in GWP are 3.5E+6 for DE and 4.64E+6 for DM, in AP are 2.63E+4 for DE and 3.38E+4 for DM, in EP are 1.13E+4 for DE and 6.99E+4 for DM and in POCP are 2.63E+3 for DE and 3.67E+3 for DM respectively. The overall cost benefits of the hybrid system are approximately € 12, 000 compared to the DE system and up to about € 662, 000 compared to the DM system.

Table 2 Case vessel specification and operation profile

Specification			
Length × Breadth × Depth	39.99 m × 12.2 m × 1.73 m		
Displacement (t)	100 tons (Steel)		
Engine configuration	Hybrid (Actual)	Alternative 1 (DE)	Alternative 2 (DM)
	360 kW × 3 sets (3.2 tons) + 350 kW lithium-ion battery × 2 sets (3.5 tons)	360 kW × 3 sets (3.2 tons)	450 kW × 2 sets (4 tons)
Operational profile			
Category	Transit	Man.	Slip
Daily operation hours	6	0.6	3.72
Required propulsion power (kW)	322	144	87

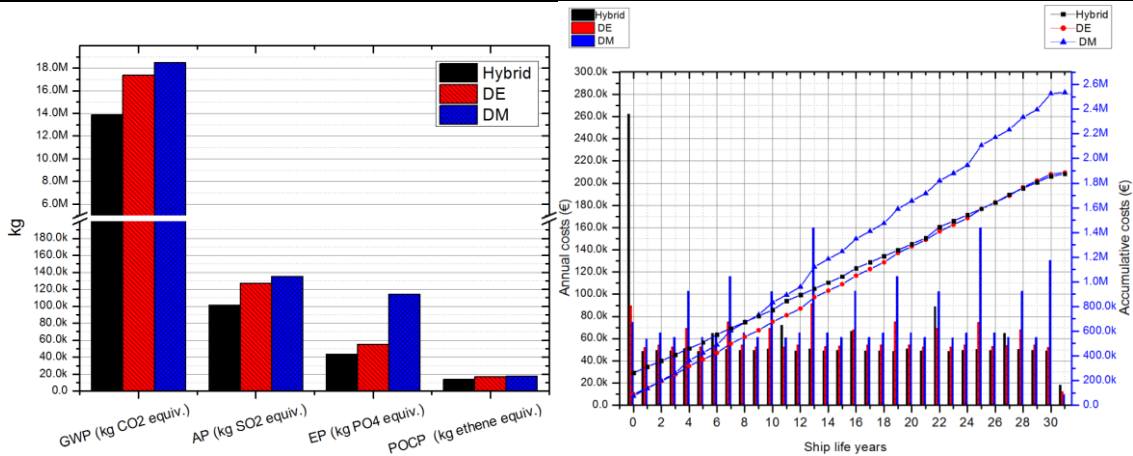

Figure 5 Results of LCA and accumulative cost over ship life years

Table 3 Vessel specifications

Length × Breadth × Depth	72.6 m × 16.0 m × 7.2 m		
Displacement (t)	2,270 tons (Steel)		
Main engine	Base MAN 4,500 kW × 720 RPM × 2 sets (each weight 51 tons)	Alternative MAN 2,220 kW × 1900 RPM × 4 sets (each weight 8.5 tons)	

#### 4.2 Selection of Engine Configuration

Apart from change engine driving principle, switching from large engines to small engines will help reduce the fuel oil consumption as well. In Figure 6 and **Error! Reference source not found.**, two layouts of the

base case and alternative are presented. The base case is to equip two 4500kW engines to drive the propellers of a ship. Under this situation, the engine output will be varied due to the operation conditions; for example, during low power load required period, such as manoeuvring, the engines will be operated under relative low power output condition which results a high

SFOC and high fuel oil consumption and emission release. The reconfiguration is trying to replace two large engines with four small engines with about half output of the large engines. While the ship experiences any required power variation or lower power requirement, it is flexible to switch off engines (such from four running engines to two) which keeps engines running at a low SFOC conditions.

Following these principles, an evaluation will be required to prove the ship performance improvements after switching propulsion system configurations in terms of economic and environmental impacts.

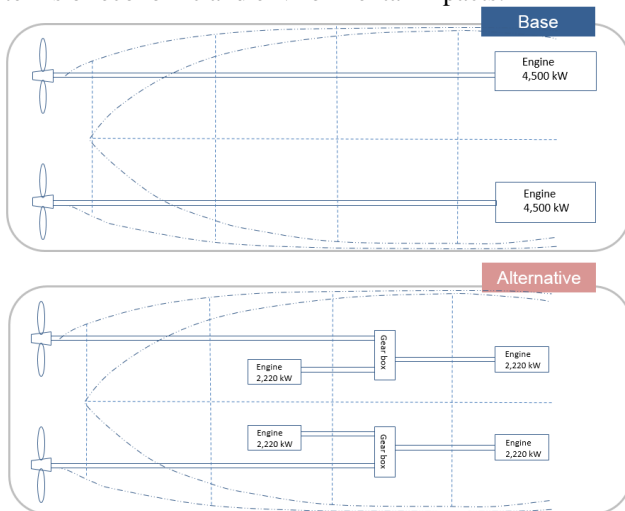

Figure 6 Layout of propulsion power system configurations.

Similar to previous study, two LCA models are established to take three life stages into account (Construction, operation, scrapping). All the activities involved are shown in the LCA models in Appendix 2 .

Based on the CML model, the gaps between the two options in the GWP was  $4.53E+7$  kg, in the AP was  $8.81E+5$  kg, in the EP was  $1.42E+5$  kg and in the POCP was  $4.73E+4$  kg. The same trend with the Case study 1 was observed that the operation phase would be the dominant life stage. This shows a gain of approximately € 3, 590, 000 when the alternative case is applied. The consideration of construction phase is the purchase, transportation, installation of the main engines. The activities considered in operation phases are mainly regarding to the fuel and lubricating oil such as purchase, transportation and emissions release. The maintenance phase considers both the spare part changes and the hull cleaning. At the end of life, the ship hull material will be cut, recycled and disposed as well as the machineries. With these considerations, both the costs of benchmark and alternative options are estimated and shown in Table 4.

### 4.3 Utilization of Solar Panel Array

Renewable energy, such as solar energy, is also a solution to reduce carbon emissions. In China, there have been many inland ferries equipped with solar panels and battery packs to capture and provide energy for ship propulsion. However, solar power is not widely used and applied on marine vessels so a case vessel who is operated in Turkey (currently no emission

regulations) is carried out. The idea of using solar energy is to make the best use of this natural power source so the priority of using it is highest. The case vessel and the integration layout are presented in Figure 7. It will first use all the solar power output to meet the power requirement and if the solar power is not sufficient, power stored in the battery packs and power generated from diesel engines will be used to fill the vacancy of power needed.

However, the application of solar system will increase the initial investment or bring considerable cost due to the installation/ retrofiting. It is significant to determine the payback time of the investment with the consideration of financial profits and environment protections.

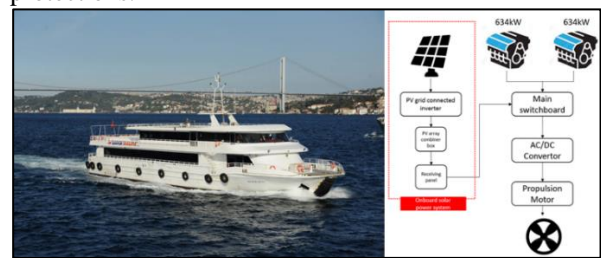

Figure 7 Outline of power distribution for case ship

The application of solar panel array is to on a short route ferry which regularly serves in the Bosphorus Strait, located in the Sea of Marmara. The ship particulars are presented in Table 5, based on which a LCA model is built in software GaBi 5 (Figure 8) considering five different flows: machineries, diesel oil, fuel oil, electricity and natural gas. Basically, these flows cover three sub-flows: energy flow, emission flow and cash flow; based on these divisions, the life cycle cost and environmental impacts can be determined and compared for two cases: with solar system and without the system.

Table 4 Life cycle cost assessment for two engine configurations.

	Phase	Cons.	Operation	Main.	Scrap.	Total
Cost (K€)	Base	752	33,607	1, 20	232	36,113
	Alternative	733	29,955	1,609	222	32,521

Unit K=1, 000

According to the evaluations, the application of solar system has no doubt in its improvement on environmental protection: 1) the solar system could reduce the global warming potential by about  $10^{10}$  kg CO<sub>2</sub> equiv.; 2) most contribution of GWP is from the operation phase which consume large quantity of fossil fuel (Figure 9). The fossil fuel consumed is reduced after application of solar panel array and the saved fuel costs are presented in Table 6 which is determined by comparison of the costs of two cases. To take the carbon credit into account, the reduced fuel consumption will lead to a decreased carbon emission and with the carbon credit price from (reference for carbon credit), the saved carbon credits can be determined.

After consideration of investment of solar panel, and the saved fuel cost and carbon credit cost, a payback time, can be easily determined for the solar panel

implementation. For this study, the payback year is 3 years with consideration of carbon credits saving.

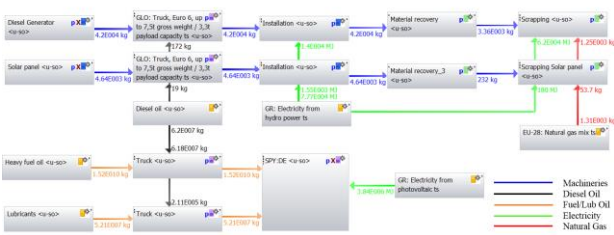

Figure 8 LCA flowchart of scenario with solar panel application

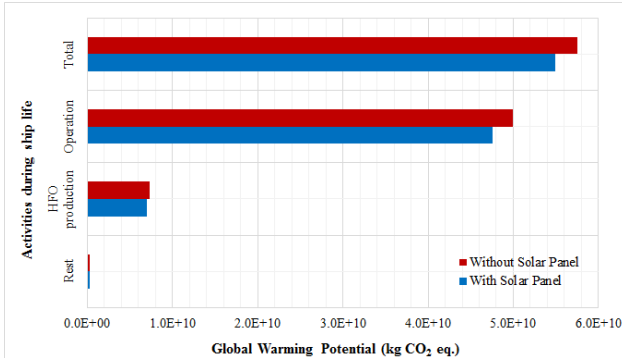
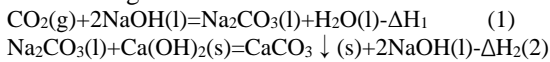

Figure 9 Comparison of GWP of two scenarios: with and without solar panel

#### 4.4 Adoption of Carbon Capture System

After-treatment is also a solution for carbon emission reduction which will apply carbon capture process to the exhaust gases from the engines. There are many ways to get the capture done such as absorption, adsorption, separation and liquefaction.

The carbon solidification method applies chemical substances to absorb and solidify carbon content from the exhaust gases. The chemical reactions [18] are listed as following:



A schematic diagram is presented in Figure 1 to indicate how these reactions are involved and applied for carbon solidification. Also the pre-treatment and after treatment are also shown in Figure 10. According to this flow diagram, the exhaust gas will be partially extracted from funnel connected with the main engines. The removals of SO<sub>x</sub> and NO<sub>x</sub> are to increase the carbon reduction efficiency because the alkaline solution (NaOH solution) will be degraded due to the presences of these acid gases. After the purification, the gas will be transported in to a physical separation process which applies membrane system to increase the purity of CO<sub>2</sub>. In this process, water, oxygen and nitrogen will be separated from CO<sub>2</sub> to obtain high concentration gas which is certainly preferred for absorption reaction. The absorption reaction with alkaline solution will take place when the gas feeding starts and after the absorption, the Na<sub>2</sub>CO<sub>3</sub> solution who contains carbon content captured will be transported for precipitation. Based on the second reaction, the sediment CaCO<sub>3</sub> will be generated which is well known in many industries as raw material,

such as building industry and medicine industry. After filtration and drying, the CaCO<sub>3</sub> powders will be stored on ship and will be traded when arrival at the destination.

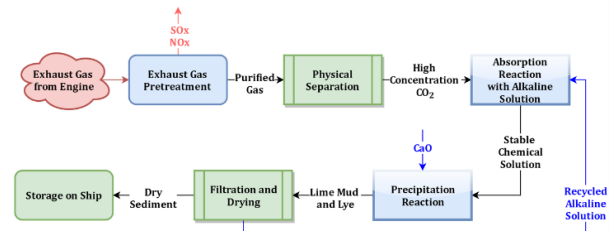

Figure 10 Schematic of chemical processes for carbon solidification on ships

The Figure 11 presents an absorption method using sodium hydroxide (NaOH) which naturally absorbs CO<sub>2</sub> and generates stable chemical compound for easy storage. During the capturing, extra energy will be consumed to run the carbon capture process so that additional carbon emissions will be released. Therefore, it is necessary to evaluate the performance of CCS while considering the extra energy used and additional emission released.



Figure 11 Experiment rig for carbon solidification process.

The application of LCA to CCS system follows the same procedures. Firstly, a case ship is selected and listed in the Table 7. The ship details will be used to establish a LCA model (Figure 12). The LCA model will cover different life stages and activities which have most significant impact on ship performances. Similarly, five different flows with three sub flows are considered in this study.

As the carbon reduction rate of CCS system could be varied, the results indicates obviously the higher carbon reduction rate will have a better GWP reduction performance (Figure 13). However, due to the energy required for the CCS system, the energy cost will be increased accordingly. With the consideration of saved carbon credits (which will be grown with an increased reduction target), it is suggesting to set the carbon

reduction rate to more than 20% will make this application (of CCS system) profitable (Table 8).

Table 5 Case study ship specifications

<b>Name</b>	<b>Hizir Reis</b>
<b>Flag</b>	Turkey
<b>LOA (m)</b>	41.98
<b>Breadth (m)</b>	10
<b>Gross tonnage (tonnes)</b>	327
<b>Engine power (kW)</b>	634×2
<b>Fuel type</b>	Heavy fuel oil (HFO)
<b>Annual operation days (days)</b>	325
<b>Ship life span (years)</b>	25
<b>Year built</b>	2012

Table 6 Annual fuel consumptions and costs for two scenarios

Item	Quantity	Units
<b>Daily fuel consumption (FC)</b>	1, 966	kg/day
<b>FC1 (6.7 hours sunny)</b>	1, 270	kg/day

<b>FC2 (3.3 hours not sunny)</b>	602	kg/day
<b>New daily FC (total)</b>	1, 872	kg/day
<b>Annual fuel consumption (benchmark)</b>	638, 961	kg
<b>Annual fuel consumption (Scenario 2)</b>	608, 489	kg
<b>Annual fuel saved</b>	30.5	tonne
<b>Fuel price</b>	351	€/tonne
<b>Annual fuel cost saved</b>	10687	€
<b>LC fuel cost saved</b>	267, 148	€
<b>Present value</b>	114, 069	€

Table 7 Case ship specification

Type	Bulk Carrier	
<b>LOA</b>	292	m
<b>LBP</b>	283.5	m
<b>Breadth</b>	45	m
<b>Depth</b>	24.8	m
<b>Draught</b>	16.5	m
<b>Gross</b>	94, 360	ton
<b>DWT</b>	157, 500	ton
<b>Water ballast</b>	78, 000	m <sup>3</sup>
<b>Fuel type</b>	HFO	

CCS system

Process plan: Reference quantities  
The names of the basic processes are shown.

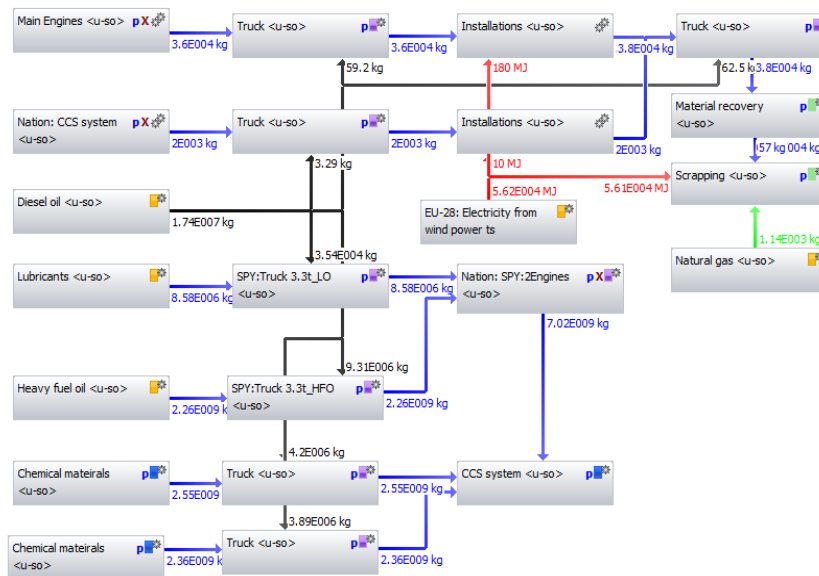

Figure 12 Full LCA model of ship.

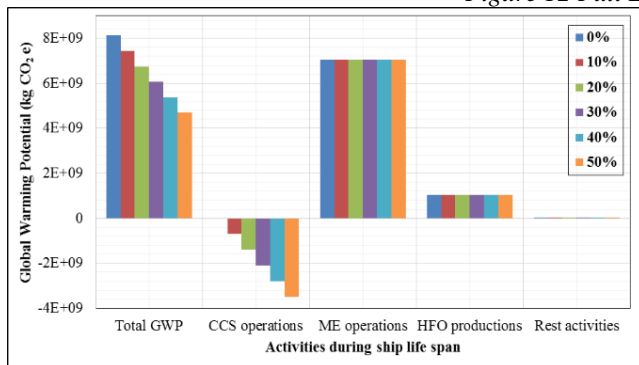

Figure 13 GWP of activities over ship life span under different carbon reduction targets

Table 8 Life cycle costs of CCS system under different reduction targets

Reduction target	Cost with CCS (€)	Cost without CCS (€)	Difference (€)
<b>0</b>	$5.17 \times 10^8$	$5.17 \times 10^8$	$0.00 \times 10^0$
<b>10%</b>	$5.24 \times 10^8$	$5.19 \times 10^8$	$-4.44 \times 10^6$
<b>20%</b>	$5.01 \times 10^8$	$5.25 \times 10^8$	$2.41 \times 10^7$
<b>30%</b>	$4.49 \times 10^8$	$5.34 \times 10^8$	$8.56 \times 10^7$
<b>40%</b>	$3.68 \times 10^8$	$5.48 \times 10^8$	$1.80 \times 10^8$
<b>50%</b>	$2.58 \times 10^8$	$5.65 \times 10^8$	$3.08 \times 10^8$

#### 4.5 Determination of Optimal Maintenance Strategy

Maintenance is an important phase during a ship's operation which increases the energy efficiency by

cleaning the surface and enhance the safety of the ship by renewing the hull plates. The reason of cleaning surface is due to the accumulation of biofouling during the ship operation in water. The accumulation will increase the roughness of the ship hull and increase the resistance of ship which leads to a high power requirement for propulsion. Usually ship operators will plan for regular cleaning of ship hull surface to smooth and increase the energy efficiency of the ship. Similarly, the steel plate renewal will be taken place to fix and replace the corrosive and damaged ones. There are five different re-coating cases are investigated (Table 10) for a case ship (Table 9). However, how regular is good enough (an optimal plan) is difficult to say because the cost investment of every entry for hull cleaning and repairing. With the help of evaluations on different maintenance plans, the performances under different plans can be derived and compared considering both the impacts of cost and environment.

*Table 9 Specifications of vessel*

Name	MV Hallaig
Gross weight	499 tons
Length	43.50 m
Breadth	12.20 m
Depth	3 m
Draught	1.73 m
Block coefficient (Cb)	0.45
Power	360 kW × 3
Superstructure decks	2
Builders	Ferguson Shipyard Ltd.
Built year	2012

*Table 10 Five maintenance strategies for the selected marine vessel*

No.	Maintenance Strategy
Case 1:	Re-coating annually;
Case 2:	Re-coating every two years;
Case 3:	Re-coating every three years;
Case 4:	Re-coating yearly and renewal hull steel every 10 years;
Case 5:	Re-coating yearly and renewal hull steel every 7 years

In the next section, five case ship studies will be presented for these mentioned CRT method and LCA

method will be applied to set up goals and scope of the analysis, determine the environmental and cost impact and provide suggestions for different CRT method applications.

The case ship involved in the study of determination of optimal maintenance plan is the ship used in hybrid propulsion system case in Section 5.1. The specification of the ship is presented in Table 9. A full LCA model is established and presented in Figure 14 considering 7 different flows: fuel, steel, material, electricity, machineries, nature gas and fuel for transportation. Again, the energy flow, emission flow and cash flow are under consideration to determine the environmental and cost impact under different maintenance strategy. As mentioned in the principle in Section 4.5, this study will consider five different plans which has been presented in Table 10.

The environmental impacts are presented in Figure 15 and it indicates the steel renewal will have a very limited impact on environmental but the coating (hull cleaning) processes will help decrease the emission release so that reduce the GWP of the ship along its life time. From Figure 14, when the cleaning is scheduled to be yearly based, the GWP has a minimal value which suggests the ship operator to carry out ship hull cleaning regularly. It is supporting the ship operator who is carrying yearly based hull cleaning.

Furthermore, the emission release reduction due to the cleaning of the hull surface is also a result of increasing of energy efficiency. Therefore, it is obvious that the fuel saved due to the cleaning of ship hull is increased while shortening the cleaning interval which keeps the surface roughness in a good condition. Apart from the cost of fuel consumption, the flow and activities of hull steel is considered: 1) purchase, 2) construction, 3) renewal, 4) recycle. With considerations on the cash flow, energy flow and emission flow, the optimal hull steel renewal interval is determined to be every 10 years which only cost €180k for 25 years' steel renewal. Figure 16 presents the relationship between the hull steel renewal interval and the life cycle cost. The steel thickness in the corrosion critical parts is 23 mm and a total steel weight of 130 tonnes. It is 15% increment in the steel thickness and 3% increase in the steel quantity.

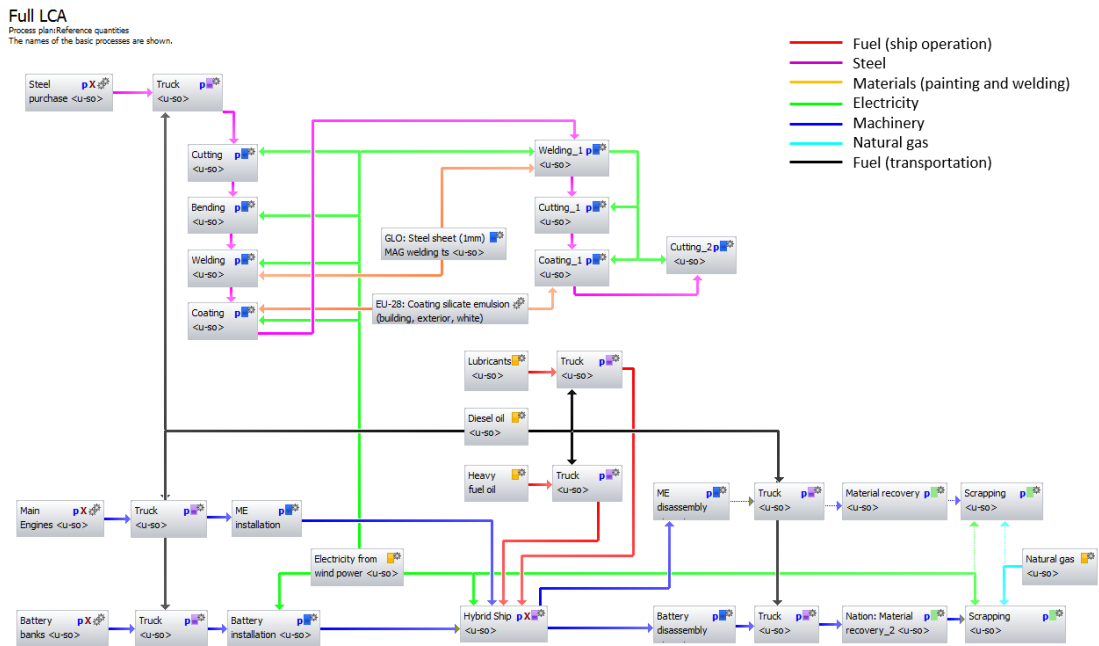

Figure 14 Flow chart of LCA model.

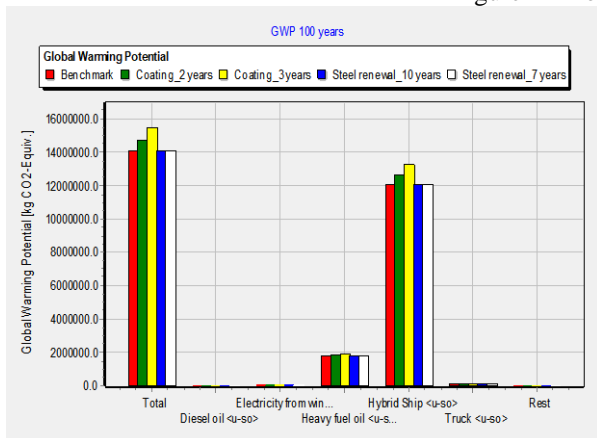

Figure 15 LCA results with application of CML 2001

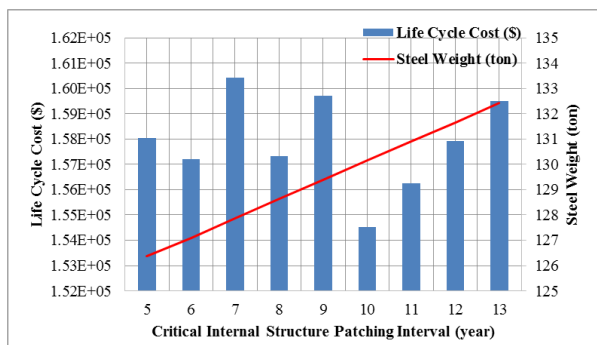

Figure 16 LCA cost and hull weight changes with steel renewal intervals.

## 5 CONCLUSION

This paper has illustrated five different performance evaluations using LCA methodology to take into account the cost and environmental impacts of different carbon emission reduction technologies applying on marine vessels.

In this paper, the performances of three different types of propulsion systems are evaluated to determine their impacts on the marine vessel cost and emission release. The comparison of their performances and impacts indicates the excellence of hybrid system on

short route ferry which is flexible to meet random variation of engine power requirements.

Another similar evaluations focusing on the configuration and selection of engines is presented in this paper. It indicates the selection of four small engines will be suitable for this tug ship whose engine power requirement is also fluctuated. With four small engines, the vessel doesn't need to run all the engines at a low power output (two large engine configuration) but only some engines at a low SFOC under same power output (four small engine configuration).

Two new generations of CRT methods are introduced in this paper, either use renewable energy or innovative treatment of exhaust gas. The performance of the vessel with and without the new technologies are examined and compared and the fuel saving and emission reduction performances of the technologies are determined. With the consideration of carbon credit saved, the total saving due to the applications are derived and the payback time of the investment are thus obtained straightforwardly.

Apart from the systems or machineries application, another LCA analysis to determine the optimal maintenance plan is carried out considering the coating and patching of ship hull. The hull coating will affect the hull roughness and the fuel oil consumptions. The steel patching and renewal will have a direct impact on the steel investment, maintenance and recycling; furthermore, behind the scene, it will increase the safety of the vessel which is not considered and quantified in this paper. With the help of LCA method, the optimal intervals of coating and patching are determined to be yearly and every 10 years respectively.

With all these evaluation processes and examples, the LCA evaluation processes are proved to have considerable of advantages as listed in the following bullet points:

- Comprehensively considering activities and life stages for ship performance evaluations;

- In every emission category, the environmental impact could be converted to one type of emission

indicator, which will be a fundamental for further decision making processes;

Three types of flows can be considered: cash, energy, emission; they could meet most the evaluation purposes with quantified results;

Based on the targets of the analysis, the aim and scope of the evaluation could be modified and provide a reasonable comparison to determine the optimal alternative;

Be able to determine different formats of results with further considerations: present value, payback period etc.;

Assumptions could be made based on experiences and practices to keep the accuracy of results in a reasonable range;

The LCA model could be modified for a new evaluation purpose with most of the general activity modules unchanged to reduce time scale of the evaluation process;

The relationships between different life stages and between different activities can be simulated in LCA model so that the interactions can be taken into account.

Therefore, it is suggested to marine industry, such as shipyards, ship operators, ship owners and policy makers to apply LCA method to evaluate the applications of CRTs to give a comprehensive and reasonable estimation on their performance on marine vessels.

## 6 ACKNOWLEDGEMENT

The authors wish to thank the Caledonian MacBrayne (CalMac Ferry Ltd) Ferries and Ferguson Marine for providing the data used in this paper. The authors also gratefully acknowledge that the research presented in this paper was partially generated as part of the HORIZON 2020 SHIPLYS (Ship life cycle software solutions) Project, Grant agreement number 690770.

## REFERENCE

- [1] Smith TWP, Jalkanen JP, Anderson BA, Corbett JJ, Faber J, Hanayama S, et al. A new scenario framework for climate change research: Background, process, and future directions. vol. 122. London, UK: 2014. doi:10.1007/s10584-013-0912-3.
- [2] Jeong B, Wang H, Oguz E, Zhou P. An effective framework for life cycle and cost assessment for marine vessels aiming to select optimal propulsion systems. *J Clean Prod* 2018;187:111–30. doi:10.1016/J.JCLEPRO.2018.03.184.
- [3] Ling-Chin J, Roskilly AP. Investigating a conventional and retrofit power plant on-board a Roll-on/Roll-off cargo ship from a sustainability perspective – A life cycle assessment case study. *Energy Convers Manag* 2016;117:305–18. doi:10.1016/J.ENCONMAN.2016.03.032.
- [4] Oguz E, Wang H, Jeong B, Zhou P. Life cycle and cost assessment on engine selection for an offshore tug vessel. In: C Guedes Soares & AP Teixeira, editor. *C Guedes Soares AP Teixeira (eds), Marit. Transp. Harvest. Sea Resour. Proc. 17th Int. Congr. Int. Marit. Assoc. Mediterr. (IMAM 2017), Lisbon, Portugal: 2017, p. 943–51.*
- [5] Wang H, Oguz E, Jeong B, Zhou P. Optimisation of operational modes of short-route ferry. 17th Int. Congr. Int. Marit. Assoc. Mediterr. Lisbon, Port. 9-11 Oct. 2017, Lisbon, Port. 9/10/17, 2017.
- [6] Trapani K, Millar DL, Smith HCM. Novel offshore application of photovoltaics in comparison to conventional marine renewable energy technologies. *Renew Energy* 2013;50:879–88. doi:10.1016/J.RENENE.2012.08.043.
- [7] CMAL. CMAL 2018. <http://www.cmassets.co.uk/ferry/mv-hallaig-2/> (accessed May 18, 2018).
- [8] CMAL. CMAL 2018. <http://www.cmassets.co.uk/ferry/mv-catriona/> (accessed May 18, 2018).
- [9] CMAL. CMAL 2018. <http://www.cmassets.co.uk/ferry/mv-lochinvar-2/> (accessed May 18, 2018).
- [10] Viking Line. Viking Line 2018. <https://www.sales.vikingline.com/find-cruise-trip/our-ships/ms-viking-grace/> (accessed May 18, 2018).
- [11] Solar Voyage. Solar Voyage 2018. <http://www.solar-voyager.com/> (accessed May 18, 2018).
- [12] Wight Link. Wight Link 2018. <http://www.wightlink.co.uk/pressrelease/wightlink-new-flagship-victoria-of-wight-is-launched/> (accessed May 18, 2018).
- [13] Hurtigeruten. Hurtigeruten 2018. <https://www.hurtigruten.co.uk/our-ships/ms-roald-amundsen/> (accessed May 18, 2018).
- [14] Poland@Sea. Poland@Sea 2018. <http://www.polandatsea.com/the-worlds-largest-plug-in-hybrid-ship-begins-to-take-form/> (accessed May 18, 2018).
- [15] Inhabitat. Inhabitat 2018. <https://inhabitat.com/solaris-is-the-33m-solar-powered-super-yacht-of-the-future/> (accessed May 18, 2018).
- [16] Ling-Chin J, Roskilly AP. A comparative life cycle assessment of marine power systems. *Energy Convers Manag* 2016;127:477–93. doi:10.1016/J.ENCONMAN.2016.09.012.
- [17] Bicer Y, Dincer I. Clean fuel options with hydrogen for sea transportation: A life cycle approach. *Int J Hydrogen Energy* 2018;43:1179–93. doi:10.1016/J.IJHYDENE.2017.10.157.
- [18] Zhou P, Wang H. Carbon capture and storage - Solidification and storage of carbon dioxide captured on ships. *Ocean Eng* 2014;91. doi:10.1016/j.oceaneng.2014.09.006.
- [19] Guedes Soares C, Garbatov Y. Reliability assessment of maintained ship hulls with correlated corroded elements. *Mar Struct* 1997;10:629–53. doi:10.1016/S0951-

- 8339(98)00004-5.
- [20] Garbatov Y, Guedes Soares C. Structural maintenance planning based on historical data of corroded deck plates of tankers. *Reliab Eng Syst Saf* 2009;94:1806–17. doi:10.1016/J.RESS.2009.05.013.
- [21] Wang G, Spencer J, Elsayed T. Estimation of Corrosion Rates of Structural Members in Oil Tankers. Vol. 3 Mater. Technol. Ocean Eng. Polar Arct. Sci. Technol. Work., ASME; 2003, p. 253–8. doi:10.1115/OMAE2003-37361.
- [22] Paik JK, Wang G, Thayamballi A-K, Lee JM, Park YI. Time-Dependent Risk Assessment of Aging Ships Accounting for General / Pit Corrosion, Fatigue Cracking and Local Denting Damage. 2003.
- [23] Ivanov L, Spencer J, Wang G. Probabilistic Evaluation of Hull Structure Renewals for Aging Ships. n.d.
- [24] Gratsos GA, Psaraftis HN, Zachariadis P. LIFE CYCLE COST OF MAINTAINING THE EFFECTIVENESS OF A SHIP'S STRUCTURE AND ENVIRONMENTAL IMPACT OF SHIP DESIGN PARAMETERS: AN UPDATE. RINA Conf. Des. Oper. Bulk Carriers, Athens, Greece: 2009.
- [25] Styles D, Börjesson P, D'Hertefeldt T, Birkhofer K, Dauber J, Adams P, et al. Climate regulation, energy provisioning and water purification: Quantifying ecosystem service delivery of bioenergy willow grown on riparian buffer zones using life cycle assessment. *Ambio* 2016;45:872–84. doi:10.1007/s13280-016-0790-9.
- [26] Vázquez-Rowe I, Villanueva-Rey P, Moreira MT, Feijoo G. Edible Protein Energy Return on Investment Ratio (ep-EROI) for Spanish Seafood Products. *Ambio* 2014;43:381–94. doi:10.1007/s13280-013-0426-2.
- [27] Fredga K, Mäler KG. Life cycle analyses and resource assessments. *Ambio* 2010;39:36–41. doi:10.1007/s13280-010-0063-y.
- [28] Al-Behadili SH, El-Osta WB. Life Cycle Assessment of Dernah (Libya) wind farm. *Renew Energy* 2015;83:1227–33. doi:10.1016/J.RENENE.2015.05.041.
- [29] Oebels KB, Pacca S. Life cycle assessment of an onshore wind farm located at the northeastern coast of Brazil. *Renew Energy* 2013;53:60–70. doi:10.1016/J.RENENE.2012.10.026.
- [30] Pascale A, Urmee T, Moore A. Life cycle assessment of a community hydroelectric power system in rural Thailand. *Renew Energy* 2011;36:2799–808. doi:10.1016/J.RENENE.2011.04.023.
- [31] Somorin TO, Di Lorenzo G, Kolios AJ. Life-cycle assessment of self-generated electricity in Nigeria and Jatropha biodiesel as an alternative power fuel. *Renew Energy* 2017;113:966–79. doi:10.1016/J.RENENE.2017.06.073.
- [32] Alkaner S, Zhou P. A comparative study on life cycle analysis of molten carbon fuel cells and diesel engines for marine application. *J Power Sources* 2006;158:188–99. doi:10.1016/J.JPOWSOUR.2005.07.076.
- [33] Blanco-Davis E, del Castillo F, Zhou P. Fouling release coating application as an environmentally efficient retrofit: a case study of a ferry-type ship. *Int J Life Cycle Assess* 2014;19:1705–15. doi:10.1007/s11367-014-0780-8.
- [34] Blanco-Davis E, Zhou P. LCA as a tool to aid in the selection of retrofitting alternatives. *Ocean Eng* 2014;77:33–41. doi:10.1016/J.OCEANENG.2013.12.010.
- [35] Koch T, Blanco-Davis E, Zhou P. Analysis of Economic and Environmental Performance of Retrofits using Simulation 2013.
- [36] Strazza C, Del Borghi A, Gallo M, Manariti R, Missanelli E. Investigation of green practices for paper use reduction onboard a cruise ship—a life cycle approach. *Int J Life Cycle Assess* 2015;20:982–93. doi:10.1007/s11367-015-0900-0.
- [37] Wang H, Oguz E, Jeong B, Zhou P. Life cycle cost and environmental impact analysis of ship hull maintenance strategies for a short route hybrid ferry. *Ocean Eng* 2018;161:20–8. doi:10.1016/J.OCEANENG.2018.04.084.
- [38] Nicolae F, Popa C, Beizadea H. APPLICATIONS OF LIFE CYCLE ASSESSMENT (LCA) IN SHIPPING INDUSTRY. GEOCONFERENCE ENERGY CLEAN Technol. VOL II, Albena, BULGARIA: STEF92 Technology Ltd; 2014, p. 289–96.
- [39] ISO. ISO 14040:2006 - Environmental management -- Life cycle assessment -- Principles and framework. Int Organ Stand Geneva, Switz 2006. <https://www.iso.org/standard/37456.html> (accessed July 18, 2018).
- [40] ISO. ISO 14044:2006 - Environmental management -- Life cycle assessment -- Requirements and guidelines. Int Organ Stand Geneva, Switz 2006. <https://www.iso.org/standard/38498.html> (accessed July 18, 2018).
- [41] CML. CML-IA Characterisation Factors - Leiden University. Inst Environ Sci 2016. <https://www.universiteitleiden.nl/en/research/research-output/science/cml-ia-characterisation-factors> (accessed July 18, 2018).

## Appendix

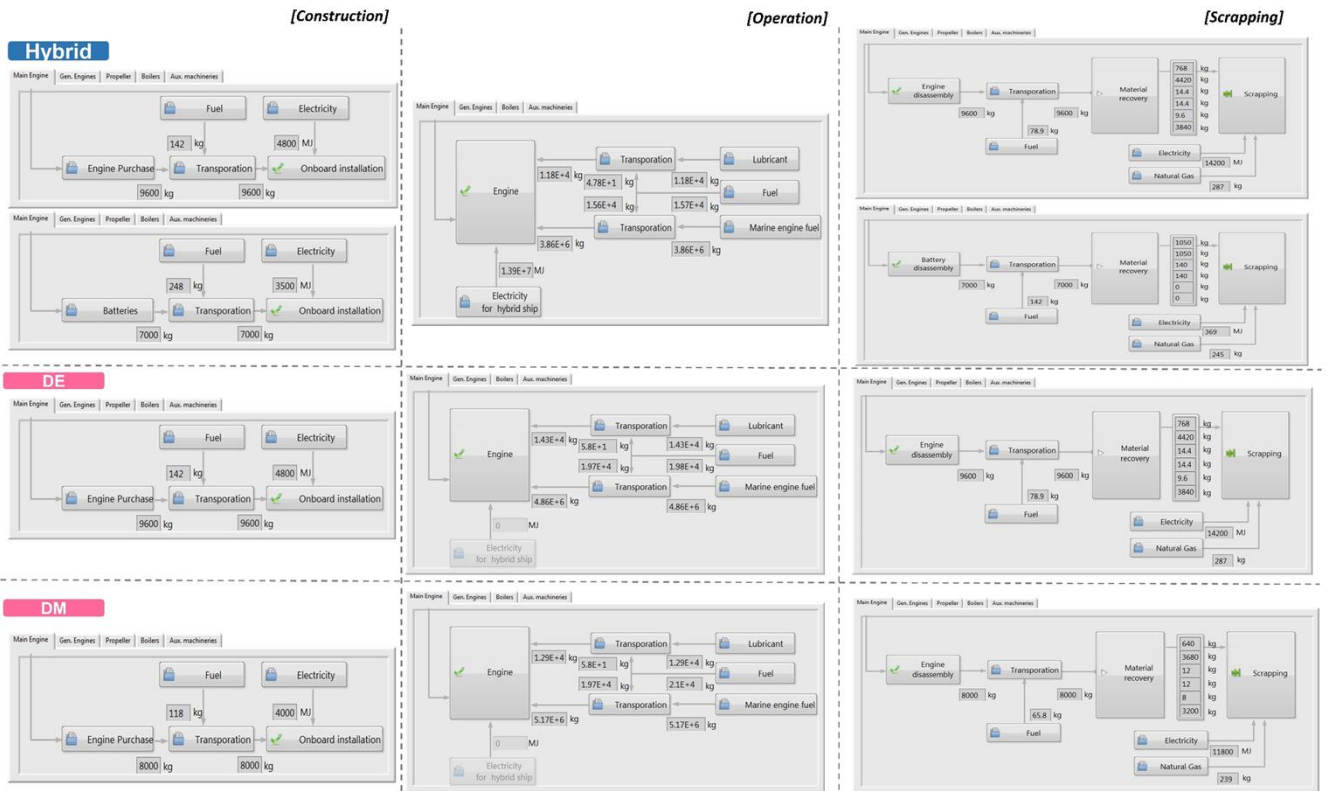

Appendix 1 Element flows for Case Study 1 (in LabVIEW Interface)

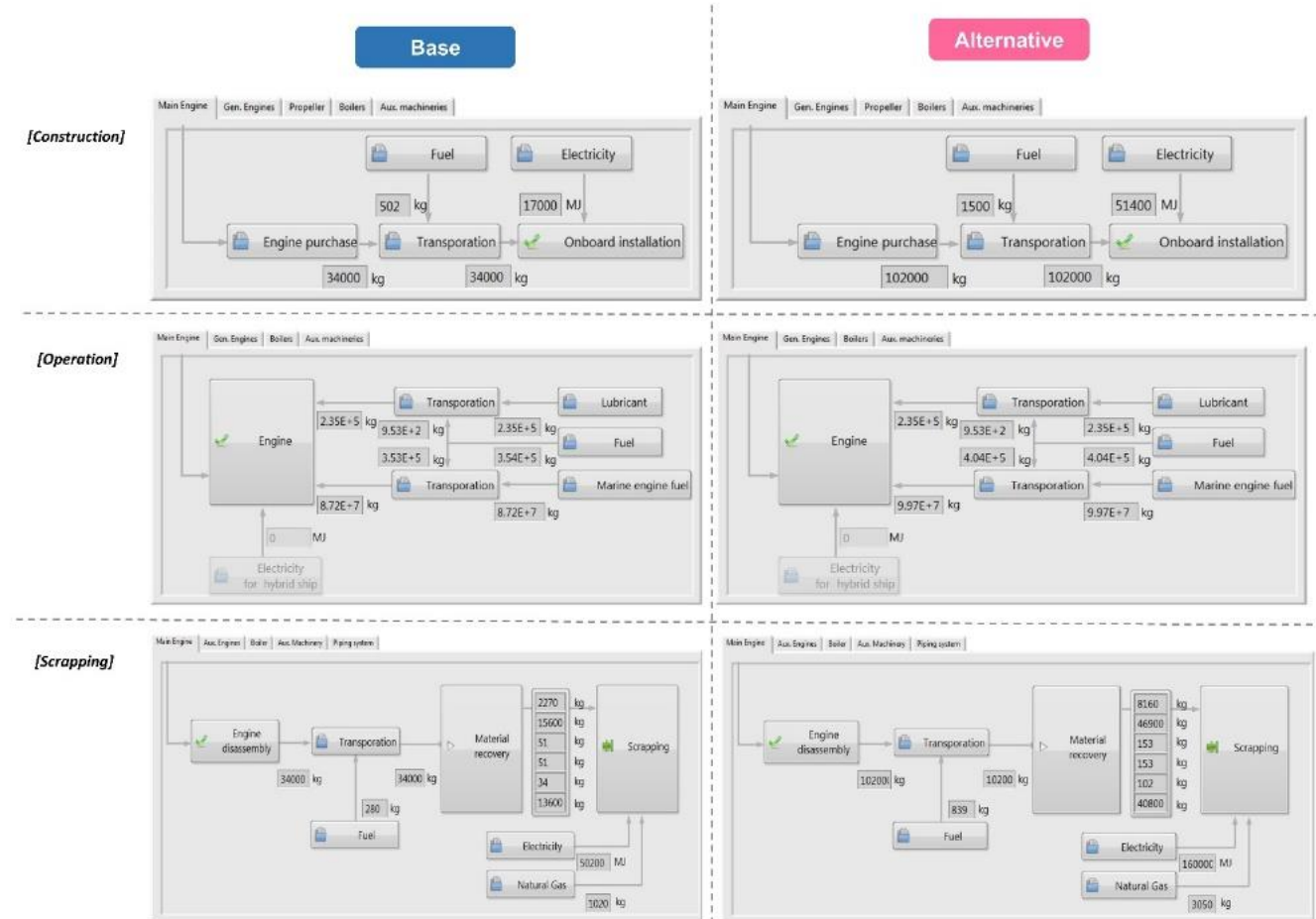

Appendix 2 Element flow for Case Study 2 (in LabVIEW interface)